

Datasheet

Salto Systems presents a wide range of standard kiosks, complete with all the necessary configurations for effortless integration into the BlueEntrance visitor management system.

This presents an ideal resolution for making the most of BlueEntrance's self-registration, check-in, and check-out features.



BlueEntrance Kiosk

Technical specifications:

Depending on the chosen functionalities within the BlueEntrance visitor management system, five standard versions are available to create the maximum visitor experience in your building.

MAIN FEATURES:

Introduction BlueEntrance Visitor Management

Explore BlueEntrance, the advanced Visitor Management solution, which is fully integrated in SALTO Space. This unique solution is designed to enhance security and provide the most welcoming experience for your guests.

When your visitor is invited by the host, the visitor will receive a confirmation mail with a QR code and PIN code. With this code, the visitor or contractor can check-in (or check-out again upon departure) via the BlueEntrance kiosk functionality. Offcourse is a selfregistration of the visitor at the kiosk available as well.

For a more comprehensive understanding of the BlueEntrance Visitor Management solution, please refer to the datasheet of BlueEntrance available.

The kiosk features in BlueEntrance

Based on the BlueEntrance setup, the next step in the registration process takes place at the kiosk. This concerns the automatic check-in of the visitor by scanning the received QR code or the self-registration of the visitor or contractor.

By default, the kiosk displays after check-in the company's safety instructions, which require approval. The final step entails providing the visitor with an access key, encode the mobile phone or the ability to print a visitor label.

Performing a validation of the person by scanning the passport or ID is one of the options of BlueEntrance within the kiosk functionalities.

Following a successful registration and authorization process, the entrance door is unlocked by interacting with the kiosk, and the host is promptly notified of the visitor's arrival.

CONFIGURATIONS:

Kiosko Model:	B002-001	B002-002	B002-003	B002-004	B002-005
27" touch monitor	•	•	•	•	•
QR reader	•	•	•	•	•
SALTO Encoder (mounting bracket built-in)	•	—	•	—	•
Card dispenser (mounting bracket built-in)	—	•	—	•	—
Labelprinter (built-in option)	—	—	•	•	—
ID scanner (built-in option)	—	—	•	•	—
Speaker	—	—	—	—	•
Microphone	—	—	—	—	•

CLIENT TECHNICAL REQUIREMENTS:

Hardware Requirement For Client: (not included)	NUC PC Processor: 1.6 GHz or higher. 32Bits or 64Bits. At least 2 CPU 2.5GHz and 4GB RAM is required. SALTO encoder Card dispenser Stickerprinter ID scanner
Software Requirements:	Web browser compatibility Google Chrome Mozilla Firefox Microsoft Edge



Standard Kiosk models

Drawing upon the capabilities offered by the BlueEntrance visitor management system, we have curated a selection of standard kiosk models.

All our kiosks come outfitted with a 27" touchscreen display, ensuring an optimal interface for navigating through the BlueEntrance workflows.

A QR reader is consistently integrated for the initial check-in process of the visitor or contractor. Furthermore, the kiosks are equipped with hardware installations for encoding visitor access keys, card dispensing, label printing, or an intercom system, all ready for convenient mounting.

KIOSK DIMENSIONS

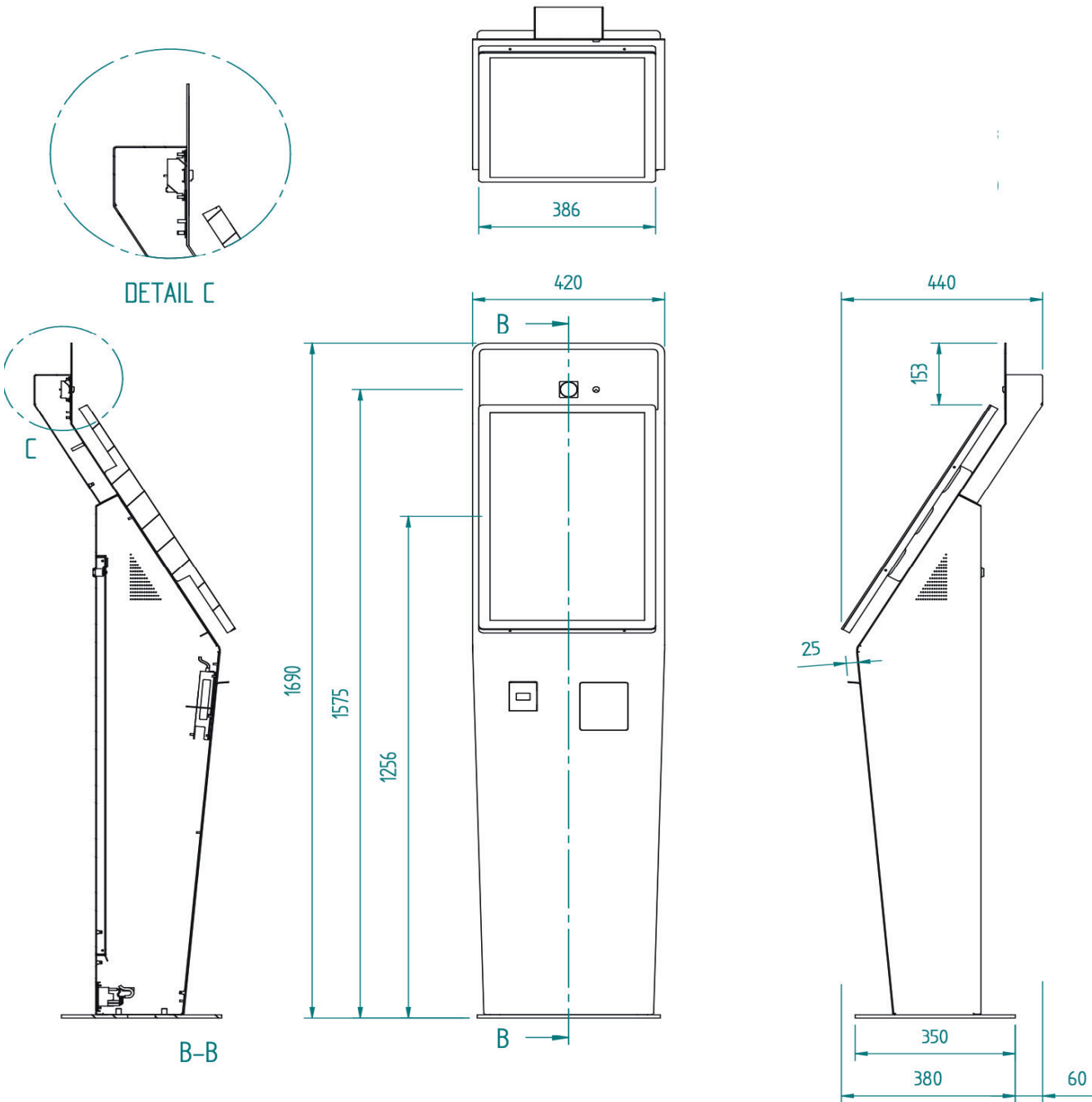

BlueEntrance Visitor Management

Integrate easily with SALTO Space smart access applications and add visitors directly into your access control systems to ensure streamlined building access.

SALTO's BlueEntrance Space delivers digital visitor registration, check-in and check-out technology, and a streamlined smart access process for building management. The advanced, all-in-one software platform provides visitors, contractors, and guests with an enhanced, streamlined, and contactless smart access experience, with a robust visitor management system and SALTO's visitor kiosk models.

This product is an innovative solution designed to keep people and buildings safe and secure while providing an enhanced visitor experience. BlueEntrance Space seamlessly integrates into SALTO Space smart access applications, including an already existing access control installation.



SALTO Systems.

Get in touch with our team.

Give us a brief summary of your needs, your next project and we'll get back to you.

Spain, UK, France, Germany, Switzerland, The Netherlands, Belgium, Poland, Slovakia, Slovenia, Czech Republic, Denmark, Norway, Sweden, Finland, Italy, Portugal, US (NYC - Atlanta - LV), Canada, Mexico, Costa Rica, Colombia, Puerto Rico, Chile, UAE, India, South Africa, Singapore, China, Hong Kong, Korea, Vietnam, Australia, New Zealand.

**saltosystems
.com**